

2019 Catalogue



Varicol

Varicol

Varicol Design Limited

50 years Design and Build.

Fume, Mist, Odour Treatment Plant and Equipment.

All rights are reserved Varicol Design Limited

Varicol Design Limited Armoury Road, Small Heath, Birmingham B11 2RH ENGLAND

Tel: +44 (0) 121 314 1191 Email: sales@varicol.co.uk website: www.varicol.co.uk

VDL/2019/02A



For 50 years we have been providing technical solutions to improving the environment for the benefit of all. Since 1993 we have provided odour and fume control and treatment systems to Hong Kong.

We are a Global provider of Engineered Corrosion Resistant Products Designed and Manufactured using, Thermo-Plastics, Composite Materials and FRP Laminates.

Glenn Williams Varicol CEO.

Varicol Project List

For further project details contact salecando@candotrading.com

VARICOL TECHNOLOGY SOLUTIONS

- POULTRY STALL VAPOURS & ODOURS.
- KITCHEN FUMES MISTS & ODOURS
- REFUSE COLLECTION POINT ODOURS VAPOURS & PARTICULATES.
- PUMPING STATION VAPOURS & ODOURS.
- SEWAGE TREATMENT WORKS VAPOURS & ODOURS.
- CHEMICAL WORKS.
- WAFER FABRICATION.
- CHEMICAL PROCESSES.
- HYDROGEN SULPHIDE GAS SCRUBBING.
- AMMONIA GAS SCRUBBING.
- NITRIC ACID SCRUBBING.
- CHLORINE GAS SCRUBBING.
- INDUSTRIAL.
- COMMERCIAL.
- MUNICIPALE.

Project Reference	Airflow m ³ /sec	Model No.	Application	Date
HK Zhuhai Macao Bridge	15.0	6116S	RCP	2018
Lok Wo Sha	8.68	11150S	Kitchen Exhaust	2016
Long Ping Station	11.0	6113S	RCP	2015
Hennessey Road	3.3	61080	RCP	2011
Wynn Theatre	5.49	22010	RCP	2009
Wynn Resort - Macau	4.7	21008	Kitchen Exhaust	2008
Wynn Resort - Macau	4.7	21008	Kitchen Exhaust	2007
Wynn Resort - Macau	7.5	21008	Kitchen Exhaust	2007
Wynn Resort - Macau	7.5	21008	Kitchen Exhaust	2007
Wynn Resort - Macau	7.5	21008	Kitchen Exhaust	2007
Mega Tower	5.58	61110	RCP	2007
Mega Tower	2.8	61080	RCP	2007
Mega Tower	1.69	61060	RCP	2007
Tai Wo Market	1.0	61040	RCP	2007
Sha Kok	1.5	21004	Poultry Stall	2007
Kowloon Station	2.36	21004	Kitchen Exhaust	2007
Kowloon Station	12.0	21020	Kitchen Exhaust	2007
Kowloon Station	12.0	21020	Kitchen Exhaust	2007
Kowloon Station	5.31	21092	Kitchen Exhaust	2007
EMSD	5.31	MS1600	Ammonia Scrubber	2005
Tiu Keng Leng	14.0	61125NS	RCP	2006
North Point	5.5	62090	RCP	2004
Western Wholesale Market	5.5	62090	RCP	2003
Western Wholesale Market	5.5	62090	RCP	2003
Fung Tak Shopping Centre	2.0	62070	RCP	2003
Hin Keng Shopping Centre	2.8	62080	RCP	2003
Hunghom Bay	7.9	21010M	Kitchen Exhaust	2000
Hunghom Bay	8.0	21010M	Kitchen Exhaust	2000

All rights are reserved Varicol Design Limited

Varicol Design Limited Armoury Road, Small Heath, Birmingham B11 2RH ENGLAND

Tel: +44 (0) 121 314 1191 Email: sales@varicol.co.uk website: www.varicol.co.uk

Varicol Project List

For further project details contact salescando@candotrading.com

Project Reference	Airflow	Model No.	Application	Date
VTC Shatin	7.0 m ³ /sec	61110	Laboratory	1999
West New Territories L/fill	8.68 m ³ /sec	21010	Kitchen Exhaust	1999
Shek O	11.0 m ³ /sec	61113	RCP	1999
North District Hospital	3.3 m ³ /sec	21007	Kitchen Exhaust	1999
Tse On Estate	5.49 m ³ /sec	22010	Poultry Stall	1999
Flying Services Headquarters	4.72 m ³ /sec	21008	Kitchen Exhaust	1999
Sheung Wan	4.68 m ³ /sec	21008	Kitchen Exhaust	1998
United Christian Hospital	7.5 m ³ /sec	21012	Kitchen Exhaust	1998
Tung Chung	7.5 m ³ /sec	61112	RCP	1998
Sai Ying Pun Market	7.5 m ³ /sec	21010	Poultry Stall	1998
Shek Yam Estate	5.58 m ³ /sec	61110	RCP	1998
Yan Chai Hospital	1.69 m ³ /sec	21004	Kitchen Exhaust	1998
Harbour Plaza Hotel	1.0 m ³ /sec	21003	Kitchen Exhaust	1998
Cheung Kong Centre	1.5 m ³ /sec	21004	Kitchen Exhaust	1998
Kwai Shing Estate Phase II	2.36 m ³ /sec	61070	RCP	1997
So Kon Po Club	3.0 m ³ /sec	21007	Kitchen Exhaust	1997
MTRC Headquarters	5.0 m ³ /sec	21009	Kitchen Exhaust	1997
Tin Shui Wai Area 3 Phase III	5.31 m ³ /sec	22010	Poultry Stall	1997
Ma On Shan Area 77	6.45 m ³ /sec	61110	RCP	1997
Ramada Plaza Shanghai	8.3 m ³ /sec	22010	Kitchen Exhaust	1997
Anchor Street	6.8 m ³ /sec	61110	RCP	1996
Government Department Quarters	8.0 m ³ /sec	61112	RCP	1996
HK Polytechnic	5.6 m ³ /sec	21010	Kitchen Exhaust	1996
TWGHWS Wong Cho Tong	3.3 m ³ /sec	21007	Kitchen Exhaust	1996
HK University Medical Complex	5.49 m ³ /sec	22010	Kitchen Exhaust	1996
Collinson Correction Institution	4.45 m ³ /sec	21008	Kitchen Exhaust	1995
TVB City	4.58 m ³ /sec	21008	Kitchen Exhaust	1995
Lan Kwai Fong	7.5 m ³ /sec	61112	RCP	1994
Landmark Phase III	5.5 m ³ /sec	22010	Kitchen Exhaust	1994
Tiu King Ling Station	7.43 m ³ /sec	61112	RCP	1994
Union Square T20	3.36 m ³ /sec	21008	Kitchen Exhaust	1993



For 50 years Varicol have been providing technical solutions to improving the environment for the benefit of all.

Since 1993 Varicol have provided odour and fume control and treatment systems to Hong Kong.

All rights are reserved Varicol Design Limited

For further information contact;

Varicol Design Limited Tel: +44 (0) 121 314 1191 Email: sales@varicol.co.uk website: www.varicol.co.uk

Varicol Series 2000 Horizontal Random Packed Pre-Filter Crossflow Unit

Application:

Kitchen Oil Mists and Odours.

Low to Medium acid/alkali/toxic
fumes/ vapours/gases.

Each unit individually designed to meet the combination of high oil mists, particulates and odour loadings.

Principle of Operation:

Each unit offered is specifically designed and built to give the maximum efficient removal of airborne contaminants within the treated airflow stream using the principles of impingement and chemical absorption. The contaminated airflow stream enters the unit in a horizontal laminar flow and encounters a pre-wash and filter followed by a cross-flow random packed section all fully irrigated to give the maximum wash rate, liquor distribution giving enhanced impingement and absorption. The random packed section offers a high surface area to airflow volume ratio to give the maximum intimate contact between the airflow and irrigation liquor. The saturated contaminates are impinged, absorbed and carried away by the re-circulating liquor to the integral liquor holding tank. The final section consists of a demister/droplet eliminator that entrains any residual droplets from the cleaned airflow stream prior to exiting the unit.

All rights are reserved Varicol Design Limited

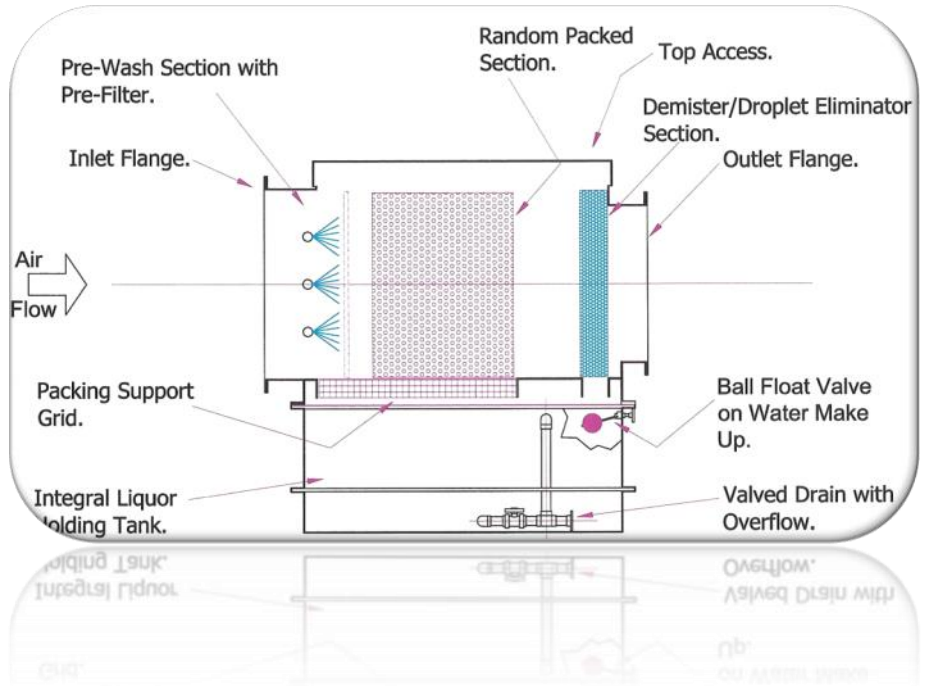

Standard Features:

Each unit offered is complete with integral liquor holding tank, pre-wash and pre-filters, high efficient random packed section, demister/droplet eliminator section, duty/standby re-circulation pumps, re-circulating irrigation system, access panels, low level switch, ball-float valve for potable water make-up and overflow with valved drain.

Optional Extras:

Inlet and outlet tapers.

Chemical day tank complete with low level switch.

Chemical metering pump with integral controller.

Compatible pH/ORP probe with needle loading valve.

For further information contact;

Varicol Design Limited Tel: +44 (0) 121 314 1191 Email: sales@varicol.co.uk website: www.varicol.co.uk

Varicol Series 2000 Horizontal Random Packed Pre-Filter Crossflow Unit

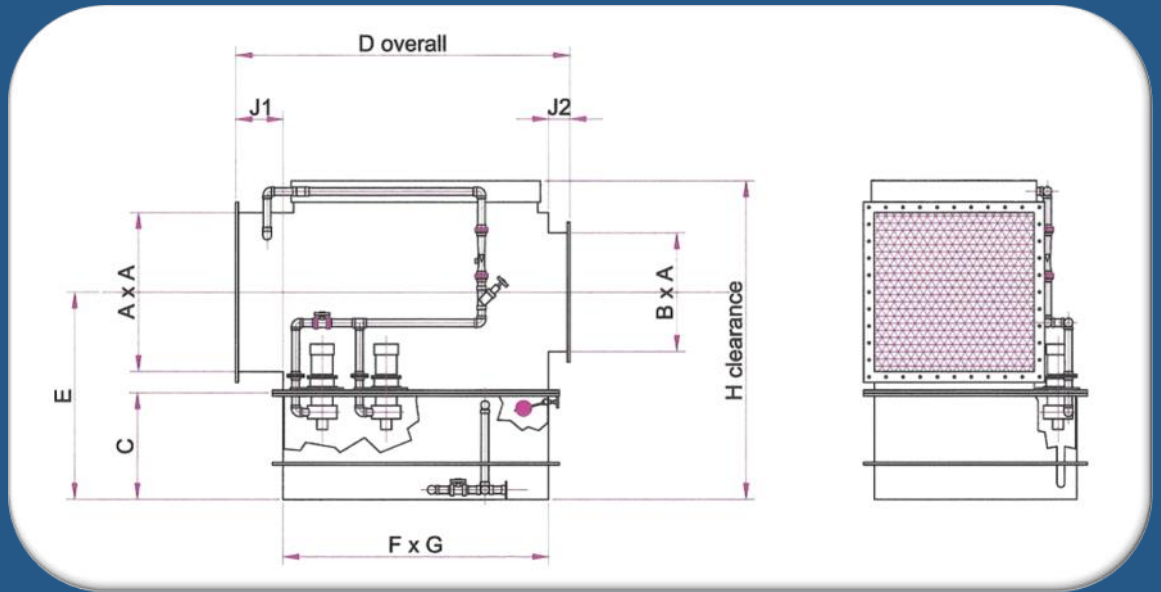

All details are for estimating purposes only.

Operational weights are approximate ONLY with integral liquor holding tank at maximum capacity.

Available Materials of

Construction:

uPVC, Polypropylene, uPVC/FRP, CPP/FRP, FRP, Fire Retardant Grade FRP.

Varicol Design Limited

Tel: +44 (0) 121 240 2716.

eMail: sales@varicol.co.uk.

Model No.	Dimension Table.										Op. Wt. (kg).
	A	B	C	D	E	F	G	H	J1	J2	
2102	620	355	500	2050	910	1600	1120	1270	350	100	1400
2104	870	500	500	2050	1035	1600	1370	1520	350	100	1700
2106	1070	600	500	2050	1215	1600	1570	1720	350	100	1900
2108	1230	690	500	2050	1290	1600	1730	1880	350	100	2100
2110	1380	770	500	2050	1355	1600	1880	2030	350	100	2400
2112	1510	840	500	2050	1415	1600	2010	2160	350	100	2600
2114	1630	910	500	2050	1470	1600	2130	2280	350	100	2750
2116	1740	970	500	2050	1520	1600	2240	2390	350	100	2900
2118	1840	1030	500	2050	1570	1600	2340	2490	350	100	3000
2120	1940	1090	500	2050	1570	1600	2440	2590	350	100	3200
2122	2040	1140	500	2050	1620	1600	2540	2690	350	100	3400
2124	2130	1190	500	2050	1685	1600	2630	2830	350	100	3500
2126	2220	1240	500	2050	1730	1600	2720	2920	350	100	3600
2128	2300	1290	500	2050	1770	1600	2800	3000	350	100	3700
2130	2380	1330	500	2050	1810	1600	2880	3080	350	100	3800
2132	2460	1370	500	2050	1850	1600	2960	3160	350	100	4000
2134	2540	1420	500	2050	1910	1600	3040	3260	350	100	4150
2136	2610	1460	500	2050	1945	1600	3110	3330	350	100	4200
2138	2680	1500	500	2050	1980	1600	3180	3400	350	100	4300

All rights are reserved Varicol Design Limited

For further information contact;

Varicol Design Limited Tel: +44 (0) 121 314 1191 Email: sales@varicol.co.uk website: www.varicol.co.uk

Varicol Series 6000 Horizontal Random Packed Crossflow Unit

Application:

Refuse Collection Point

Low/Medium/High odours/acid/
alkali/toxic fumes/vapours/gases.

Each unit individually designed to meet the combination of high oil mists, particulates and odour loadings.

Principle of Operation:

Each unit offered is fully integrated to give the maximum efficient removal of airborne contaminants within the treated airflow stream using the principles of impingement and chemical absorption. The contaminated airflow stream enters the unit in a horizontal laminar flow and encounters a cross-flow random packed section all fully irrigated to give the maximum wash rate, liquor distribution giving enhanced impingement and absorption. The random packed section offers a high surface area to airflow volume ratio to give the maximum intimate contact between the airflow and irrigation liquor. The saturated contaminates are impinged, absorbed and carried away by the re-circulating liquor to the integral liquor holding tank. The final section consists of a demister/droplet eliminator that entrains any residual droplets from the cleaned airflow stream prior to exiting the unit.

All rights are reserved Varicol Design Limited

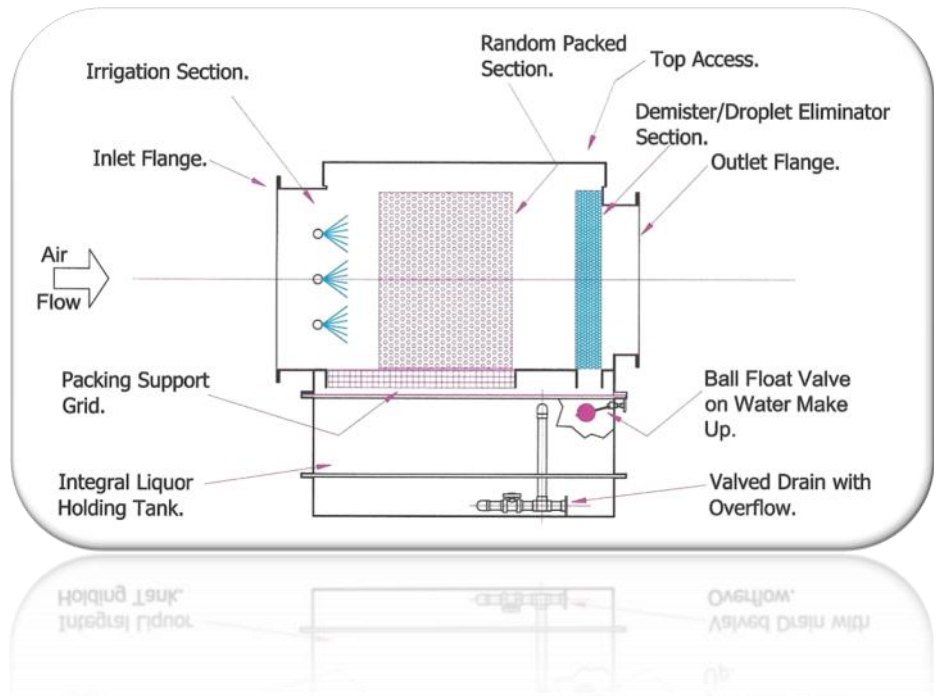

Standard Features:

Each unit offered is complete with integral liquor holding tank, pre-wash and pre-filters, high efficient random packed section, demister/droplet eliminator section, duty/standby re-circulation pumps, re-circulating irrigation system, access panels, low level switch, ball-float valve for potable water make-up and overflow with valved drain.

Optional Extras:

- Inlet and outlet tapers.
- Chemical day tank complete with low level switch.
- Chemical metering pump with integral controller.
- Compatible pH/ORP probe with needle loading valve.

For further information contact;

Varicol Design Limited Tel: +44 (0) 121 314 1191 Email: sales@varicol.co.uk website: www.varicol.co.uk

Varicol Series 6000 Horizontal Random Packed Crossflow Unit

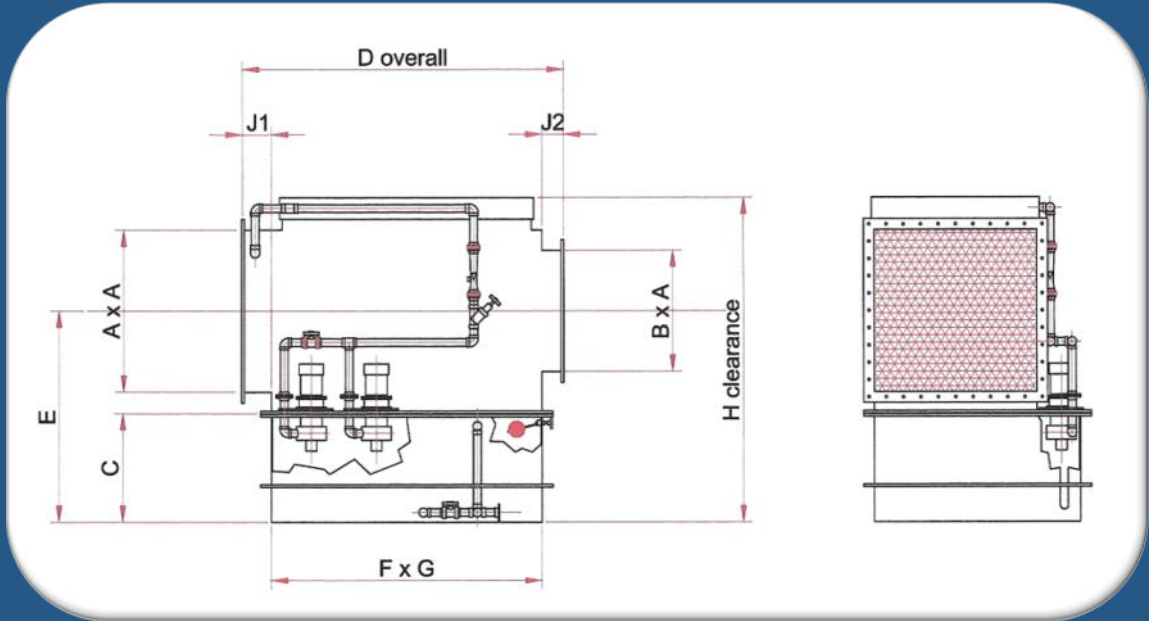

All details are for estimating purposes only.

Operational weights are approximate ONLY with integral liquor holding tank at maximum capacity.

Available Materials of

Construction:

uPVC, Polypropylene, uPVC/FRP, CPP/FRP, FRP, Fire Retardant Grade FRP.

Varicol

Varicol Design Limited

Tel: +44 (0) 121 314 1191.

eMail: sales@varicol.co.uk.

Model No.	Dimension Table.										Op. Wt. (kg).
	A	B	C	D	E	F	G	H	J1	J2	
6101	400	200	400	2000	700	1800	900	950	100	100	980
6102	500	250	400	2000	750	1800	1000	1050	100	100	1090
6103	600	315	400	2000	800	1800	1100	1150	100	100	1200
6104	700	355	500	2000	950	1800	1200	1350	100	100	1630
6105	800	400	500	2000	1000	1800	1300	1450	100	100	1770
6106	900	450	500	2000	1050	1800	1400	1550	100	100	1900
6107	1000	500	500	2000	1100	1800	1500	1650	100	100	2040
6108	1200	600	500	2000	1200	1800	1700	1850	100	100	2310
6109	1400	700	500	2000	1300	1800	1900	2050	100	100	2800
6110	1600	800	500	2000	1400	1800	2100	2250	100	100	3090
6111	1800	900	500	2000	1500	1800	2300	2450	100	100	3400
6112	2000	1000	500	2000	1600	1800	2500	2650	100	100	3680
6113	2200	1100	500	2000	1720	1800	2700	2900	100	100	3970
6114	2400	1200	500	2000	1820	1800	2900	3100	100	100	4270
6115	2600	1300	500	2000	1940	1800	3100	3320	100	100	4560
6116	2800	1400	500	2000	2040	1800	3300	3520	100	100	4860
6117	3000	1500	500	2000	2160	1800	3500	3740	100	100	5540
6118	3200	1600	500	2000	2260	1800	3700	3940	100	100	5860
6119	3400	1700	500	2000	2360	1800	3900	4140	100	100	6180

All rights are reserved Varicol Design Lim-

For further information contact;

Varicol Design Limited Tel: +44 (0) 121 314 1191 Email: sales@varicol.co.uk website: www.varicol.co.uk

Varicol Series 8000 Horizontal Multi-Throat Venturi Random Packed Crossflow

Application:

Any application treating a combination of;
High Levels of Particulates.
Heavy Oils, Mist or Vapour loadings.
High Odour loadings.
High Levels of Acid/Alkali/Toxic Gases, Fumes or Vapours.

Principle of Operation:

Each unit offered is fully integrated to give the maximum efficient removal of airborne contaminants within the treated airflow stream using the principles of impingement and chemical absorption. The contaminated airflow stream enters the unit in a horizontal laminar flow and encounters a multi-throat venturi followed by a cross-flow random packed section all fully irrigated to give the maximum wash rate, liquor distribution giving enhanced impingement and absorption. The random packed section offers a high surface area to airflow volume ratio to give the maximum intimate contact between the airflow and irrigation liquor. The saturated contaminants are impinged, absorbed and carried away by the re-circulating liquor to the integral liquor holding tank. The final section consists of a demister/droplet eliminator that entrains any residual droplets from the cleaned airflow stream prior to exiting the unit.

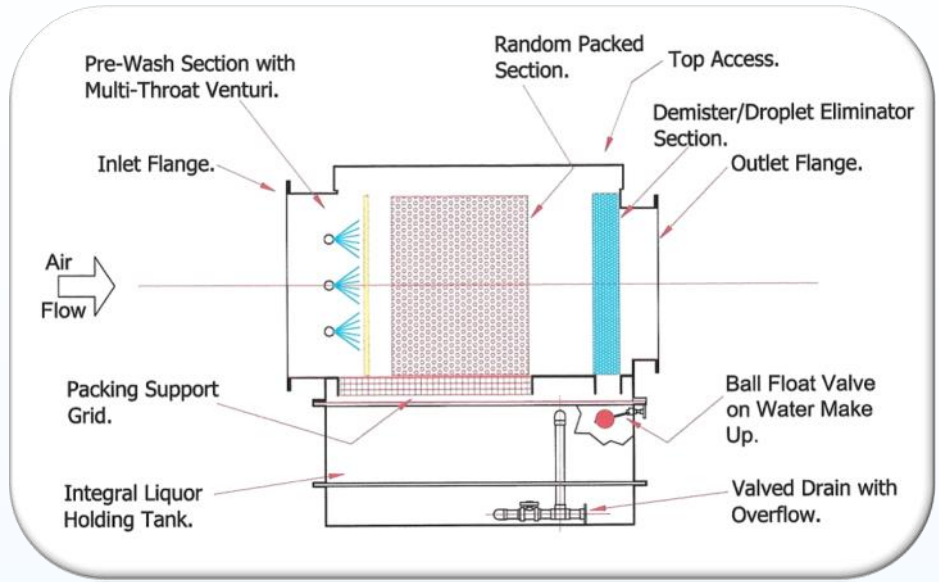

Standard Features:

Each unit offered is complete with integral liquor holding tank, multi-throat venturi pre-filter, high efficient random packed section, demister/droplet eliminator section, duty/standby re-circulation pumps, re-circulating irrigation system, access panels, low level switch, ball-float valve for potable water make-up and overflow with valved drain.

Optional Extras:

- Inlet and outlet tapers.
- Chemical day tank complete with low level switch.
- Chemical metering pump with integral controller.
- Compatible pH/ORP probe with needle loading valve.

Varicol Series 8000 Horizontal Multi-Throat Random Packed Crossflow Unit

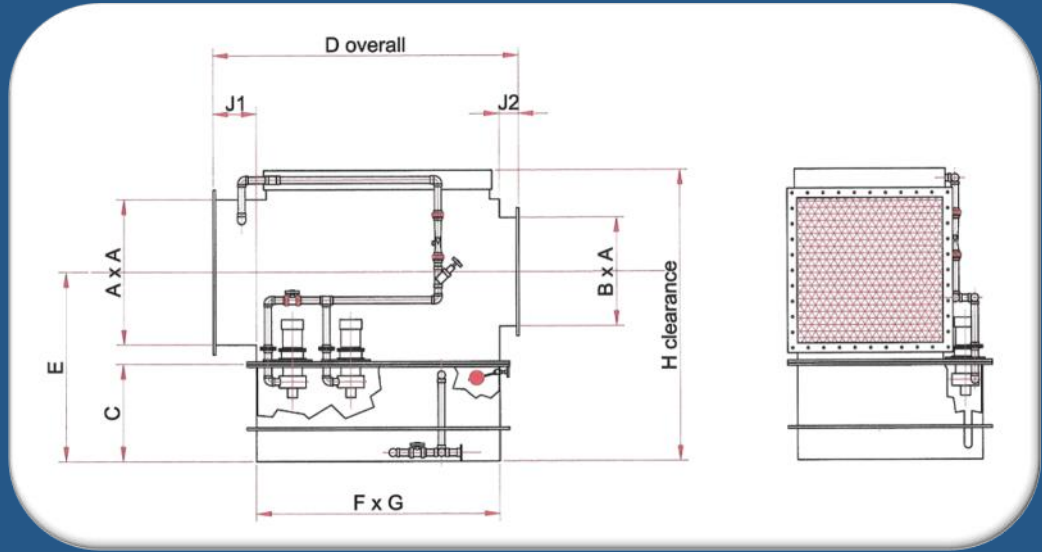

All details are for estimating purposes only.

Operational weights are approximate ONLY with integral liquor holding tank at maximum capacity.

Available Materials of

Construction:

uPVC, Polypropylene, uPVC/FRP, CPP/FRP, FRP, Fire Retardant Grade FRP.

Varicol

Varicol Design Limited

Tel: +44 (0) 121 314 1191.

eMail: sales@varicol.co.uk.

Model No.	Dimension Table.										Op. Wt. (kg).
	A	B	C	D	E	F	G	H	J1	J2	
8101	400	200	400	2100	700	1600	900	950	400	100	980
8102	500	250	400	2100	750	1600	1000	1050	400	100	1090
8103	600	315	400	2100	800	1600	1100	1150	400	100	1200
8104	700	355	500	2100	950	1600	1200	1350	400	100	1630
8105	800	400	500	2100	1000	1600	1300	1450	400	100	1770
8106	900	450	500	2100	1050	1600	1400	1550	400	100	1900
8107	1000	500	500	2100	1100	1600	1500	1650	400	100	2040
8108	1200	600	500	2100	1200	1600	1700	1850	400	100	2310
8109	1400	700	500	2100	1300	1600	1900	2050	400	100	2800
8110	1600	800	500	2100	1400	1600	2100	2250	400	100	3090
8111	1800	900	500	2100	1500	1600	2300	2450	400	100	3400
8112	2000	1000	500	2100	1600	1600	2500	2650	400	100	3680
8113	2200	1100	500	2100	1720	1600	2700	2900	400	100	3970
8114	2400	1200	500	2100	1820	1600	2900	3100	400	100	4270
8115	2600	1300	500	2100	1940	1600	3100	3320	400	100	4560
8116	2800	1400	500	2100	2040	1600	3300	3520	400	100	4860
8117	3000	1500	500	2100	2160	1600	3500	3740	400	100	5540
8118	3200	1600	500	2100	2260	1600	3700	3940	400	100	5860
8119	3400	1700	500	2100	2360	1600	3900	4140	400	100	6180

All rights are reserved Varicol Design Limited

For further information contact;

Varicol Design Limited Tel: +44 (0) 121 314 1191 Email: sales@varicol.co.uk website: www.varicol.co.uk

Varicol Series 10000 Integrate Horizontal Cross- Flow Random Packed

Application:

Refuse Collection Point

Low/Medium/High odours/acid/
alkali/toxic fumes/vapours/gases.

Each unit individually designed to meet the combination of high oil mists, particulates and odour loadings.

Principle of Operation:

Each unit offered is fully integrated to give the maximum efficient removal of airborne contaminants within the treated airflow stream using the principles of impingement and chemical absorption. The contaminated airflow stream enters the unit in a horizontal laminar flow and encounters a cross-flow random packed section all fully irrigated to give the maximum wash rate, liquor distribution giving enhanced impingement and absorption. The random packed section offers a high surface area to airflow volume ratio to give the maximum intimate contact between the airflow and irrigation liquor. The saturated contaminants are impinged, absorbed and carried away by the re-circulating liquor to the integral liquor holding tank. The final section consists of a demister/droplet eliminator that entrains any residual droplets from the cleaned airflow stream prior to exiting the unit.

Key Benefits:

Fully factory assembled and function tested.
Reduced installation time and set-up costs.
High efficient & safe chemical management & control.
Chemical spill containment.
Environmentally friendly operation.



Standard Features:

Each unit offered is complete with integral liquor holding tank with 110% capacity bund for single or dual chemical dosing, pre-wash and pre-filters, high efficient random packed section, demister/droplet eliminator section, duty/standby re-circulation pumps, re-circulating irrigation system, access panels, low level switch, ball-float valve for potable water make-up and overflow with valved drain.

Optional Extras:

Inlet and outlet tapers.
Chemical day tank complete with low level switch.
Chemical metering pump with integral controller.
Compatible pH/ORP probe with needle loading valve.

All rights are reserved Varicol Design Limited

For further information contact;

Varicol Design Limited Tel: +44 (0) 121 314 1191 Email: sales@varicol.co.uk website: www.varicol.co.uk

Varicol Series 10000 Integrated Horizontal Crossflow Random Packed

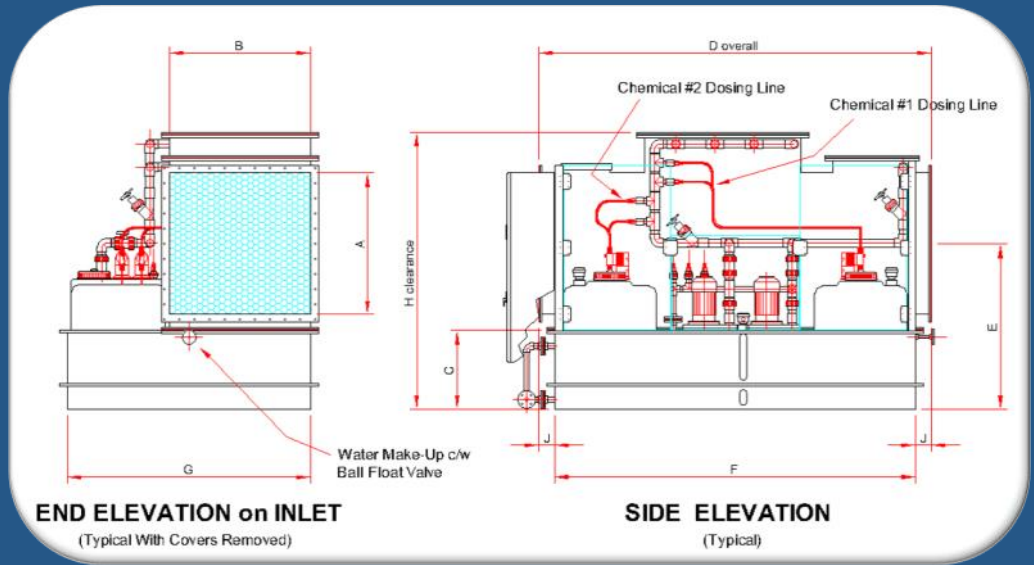

All details are for estimating purposes only.

Operational weights are approximate ONLY with integral liquor holding tank at maximum capacity.

Available Materials of

Construction:

uPVC, Polypropylene, uPVC/FRP, CPP/FRP, FRP, Fire Retardant Grade FRP.

Varicol

Varicol Design Limited

Tel: +44 (0) 121 314 1191

eMail: sales@varicol.co.uk.

Model No.	Dimension Table.										Op. Wt. (kg).
	A	B	C	D	E	F	G	H	J1	J2	
10010	400	400	500	2100	800	1900	1150	1100	100	100	1100
10020	500	500	500	2100	850	1900	1250	1200	100	100	1300
10030	600	600	500	2100	900	1900	1350	1300	100	100	1500
10040	700	700	500	2100	950	1900	1450	1400	100	100	1700
10050	800	800	500	2100	1000	1900	1550	1500	100	100	1900
10060	900	900	500	2100	1050	1900	1650	1600	100	100	2100
10070	1000	1000	500	2100	1100	1900	1750	1700	100	100	2300
10080	1200	1200	500	2100	1200	1900	1850	1800	100	100	2500
10090	1300	1300	500	2100	1250	1900	1950	1900	100	100	2700
10100	1400	1400	500	2100	1300	1900	2050	2000	100	100	2900
10110	1500	1500	500	2100	1350	1900	2150	2100	100	100	3100
10120	1600	1600	500	2100	1400	1900	2250	2200	100	100	3300
10130	1700	1700	500	2100	1450	1900	2350	2300	100	100	3500
10140	1800	1800	500	2100	1500	1900	2450	2400	100	100	3700
10150	1900	1900	500	2100	1550	1900	2550	2500	100	100	3900
10160	2000	2000	500	2100	1600	1900	2650	2600	100	100	4100
10170	2100	2100	500	2100	1650	1900	2750	2700	100	100	4300
10180	2200	2200	500	2100	1700	1900	2850	2800	100	100	4500
10190	2300	2300	500	2100	1750	1900	2950	2900	100	100	4700

All rights are reserved Varicol Design Limited

For further information contact;

Varicol Design Limited Tel: +44 (0) 121 314 1191 Email: sales@varicol.co.uk website: www.varicol.co.uk



Irrigation Pumps



VSL VERTICAL SUBMERSIBLE PUMP.

The VSL range of Vertical Submersible Pumps are built specifically for highly corrosive applications. This range provide a cost effective and efficient solution to any aggressive liquor transfer application. The double impeller pump design feature of this range requires no mechanical seal enabling these pumps to run dry. A unique rotating baffle protects the motor bearings from harmful and corrosive fumes and vapours. All wetted parts are fully corrosion proof available in Polypropylene, PVC, PVDF or 316 stainless steel.

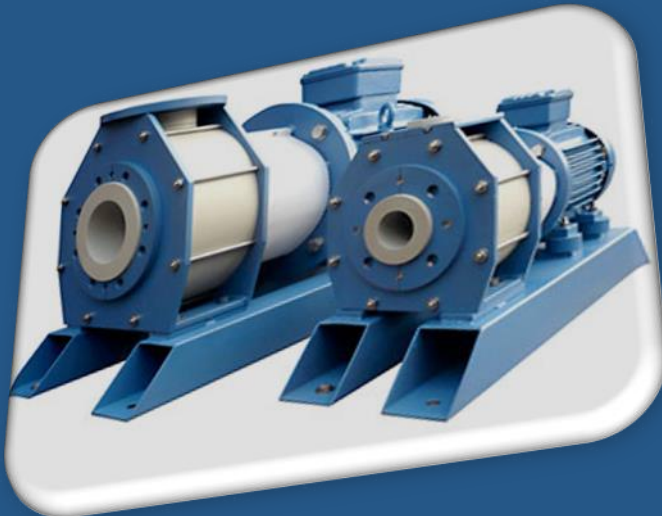

EEC-B MECHANICAL SEAL CHEMICAL PUMP.

The ECC-B Range of Mechanical Seal Chemical Pumps are design and built to exacting standards for some of the most corrosive industry applications. All wetted parts are machine from solid plastic materials for the ultimate in robust construction with all the pipeline forces being absorbed by a rugged coated steel shell. Each sleeved stainless steel drive shaft are oversized to eliminate any shaft deflection and increase the operation life of the mechanical seal reducing maintenance downtimes and operating costs. This range of pumps is available in Polypropylene, PVC, PVDF or PTFE.

The AMX range of Magnetic Drive Pumps are designed to give long service lives with a high operating efficiency. Robust and built to withstand tough conditions of high temperatures, pressures and corrosive applications. The immense efficiency of the AMX range reduces energy consumption and operating costs. The AMX range is built to last offering a patented buffer design system which absorbs vibrations and shocks caused by adverse operating conditions, increases the time between service maintenance. With its energy efficiency and durability this pumps is good news for reducing your operating costs as well as making the pump more eco-friendly.



AMX PLASTIC MAGNETIC DRIVE PUMP.

All rights are reserved Varicol Design Limited

For further information contact;

Varicol Design Limited Tel: +44 (0) 121 314 1191 Email: sales@varicol.co.uk website: www.varicol.co.uk



Varicol

Chemical Dosing



Dosing by pH using Sodium Hydroxide (NaOH)
Dosing by ORP using Sodium Hypochlorite (NaOCl)
Dosing limits controlled by eONE metering pumps' integrated controller giving accurate and efficient dosing while avoiding the additional cost of providing a separate control panel mounted controller.

The irrigation delivery rate is controlled by a manually set diaphragm valve and variable area flow meter. The flow meter is fitted with a limit switch which is activated when the flow meter float passes. The limit switch enables the use of flow status lamps and facilitates duty/standby pump enabling on flow failure.



The quality of the irrigation liquor is monitored by both pH and ORP probes. For accurate and efficient sampling each probe is installed in the irrigation delivery line just prior to the variable area flow meter. The chemicals are injected where they are most needed, at the point of delivery via a needle valve.

This system gives the ultimate in chemical delivery saving costs and reducing any environmental impact.





Reaction Process

The mass transfer rate of which Hydrogen Sulphide is absorbed is controlled by the rate at which the liquor can absorb the gas.

A gas stream contaminant must pass from the main body of gas through the gas film, then through the liquid film before being dissolved into the main body of liquid.

This is determined by the gas-film resistance operating in series with the liquid-film resistance.

The film that facilitates the predominant mass transfer resistance is called the controlling film.



When a chemical reaction is introduced by the use of a sodium hydroxide/sodium hypochlorite solution the complex nature of the reaction reduces the effect of any intermediate sulphur complexes present in the gas stream.

As a consequence the rate of absorption has a net increase in accordance with the increased rate of the reaction.

All rights are reserved Varicol Design Limited

For further information contact;

Varicol Design Limited Tel: +44 (0) 121 314 1191 Email: sales@varicol.co.uk website: www.varicol.co.uk



The treatment of Hydrogen Sulphide (H₂S) by reaction with Sodium Hydroxide (NaOH) and Sodium Hypochlorite (NaOCl).

Chemical Reaction



NaOH absorbs H₂S to form a sulphite.
NaOCl oxidises the sulphite to a more stable sulphate.
The NaOH is controlled by pH.
The NaOCl is controlled by measuring ORP (oxygen reduction potential).

The chemical consumption based on 10ppm H₂S in a airflow of 10,000cu.m/hr.

27% Sodium Hydroxide = 0.93kg/hr.

15% Sodium Hypochlorite = 6.21kg/hr.



Carbon Absorption

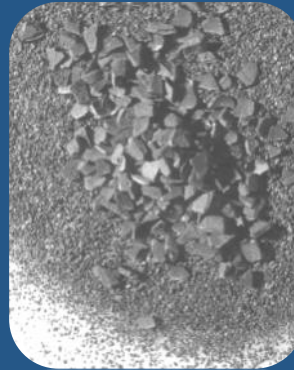

The Na₂SO₄ is absorbed onto the carbon.



PASSIVE CARBON ABSORBER UNITS.

Effective odour abatement for sensitive locations.

Varicol are a technical solutions provider of activated carbon-based passive odour control units.

Our range of passive units are commonly found adsorbing vented odourous gases from sewerage pipelines and wells.

Built to exacting quality and standards the Varicol solution guarantee effective odour control treatment and hydrogen sulphide removal.

The units are provided for use with activated carbon in granular or pellet form complete with a choice of disposable or refillable filter.

Our innovative bespoke designs act to disguise the units in places where odour control is required to be discreet.



FRP ARCHITECTURAL CONCEALMENT

Varicol is a leading exponent of using GRP for a range of architectural solutions. Working closely with contractors, planning officers and architects FRP has shown to be the perfect way of replacing a valued feature or disguising others providing concealment solutions and blending seamlessly into the existing environment.

All rights are reserved Varicol Design Limited

For further information contact;

Varicol Design Limited Tel: +44 (0) 121 314 1191 Email: sales@varicol.co.uk website: www.varicol.co.uk



Carbon Absorption

Varicol's 50yrs experience and unique capabilities offer a range of impregnated carbon de-odourising units each designed to meet your specific odour removal needs, selecting the optimum purifying media for the efficient removal of

- ◇ Hydrogen Sulphide.
- ◇ Mercaptans.
- ◇ Ammonia.
- ◇ VOC's.



Varicol offer

- ◇ Complete support through adsorption technology selection & planning process
- ◇ Full design engineering, manufacture, installation, testing and commissioning.
- ◇ The ability to achieve up to 100% removal efficiency.
- ◇ The ability to treat high flow rates.
- ◇ Technical solutions to treat variable loads of contaminant fumes/mists/vapours/odours/gases.

Varicol Technical Solutions

Supporting You with.

- ◇ Comprehensive range of activated & impregnated carbon, oxidising & multi-media filters.
- ◇ Primary, secondary or tertiary treatments.
- ◇ Dry media filters requiring no operator intervention.
- ◇ Bespoke treatment of H₂S, mercaptans, organic sulphides, ammonia, amines or VOC combinations.
- ◇ Designs built to BS4994 in our own state-of-the art manufacturing facility.

All rights are reserved Varicol Design Limited

For further information contact;

Varicol Design Limited Tel: +44 (0) 121 314 1191 Email: sales@varicol.co.uk website: www.varicol.co.uk

CARBON FILTER UNITS



Carbon Absorption

STAND ALONE UNITS

Stand alone units can be provided as a single pass full duty or single pass half duty in either negative or positive pressure arrangements.

- Optional Extra's
- Extraction Fan Unit Set.
- Set Interconnecting Ductwork.
- Free Standing Discharge Stack.
- Integral Discharge Stack (positive pressure units only).
- By-Pass Ductwork.

PACKAGED PLANTS

Packaged plant sets are available either skid mounted in or works or suitable for mounting on a slab (by others).

The sets include Carbon Absorber Unit, Duty/Standby Fans, Discharge Stack, Set Interconnecting Ductwork.

- Optional Extra's
- Local Control Panel.
- By-Pass Ductwork.

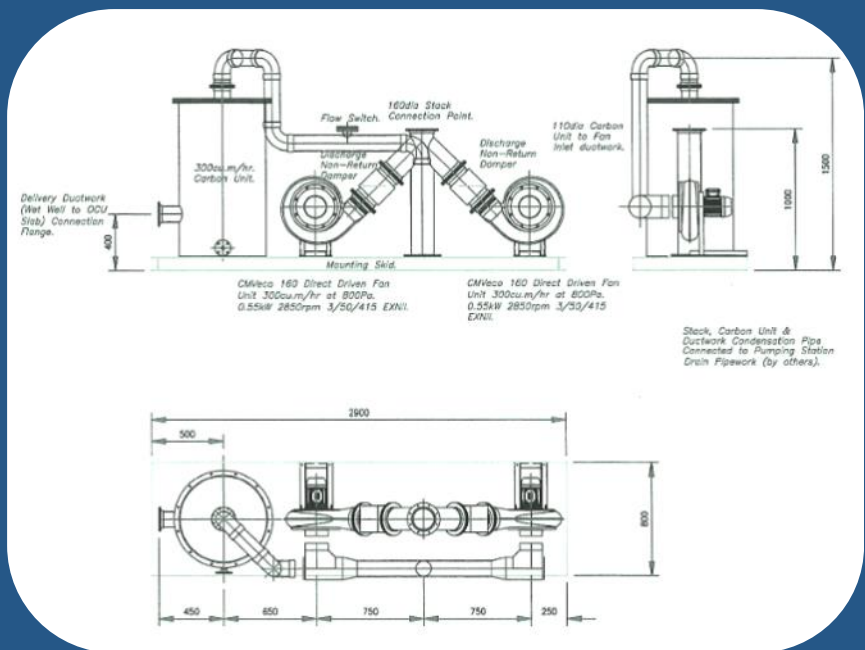

OPTIONS

- ◇ Comprehensive range of materials.
- ◇ Cost effective standard range.
- ◇ Bespoke innovative designs.
- ◇ Disposable or fillable filters.
- ◇ Forced ventilation (negative pressure).
- ◇ Forced ventilation (positive pressure).

APPLICATIONS

- ◇ Sludge De-Watering.
- ◇ Pumping Stations.
- ◇ Wastewater Treatment Works.
- ◇ Primary/Secondary/Tertiary Treatment.
- ◇ Odour Polishing.
- ◇ VOC Removal.

All rights are reserved Varicol Design Limited

For further information contact;

Varicol Design Limited Tel: +44 (0) 121 314 1191 Email: sales@varicol.co.uk website: www.varicol.co.uk

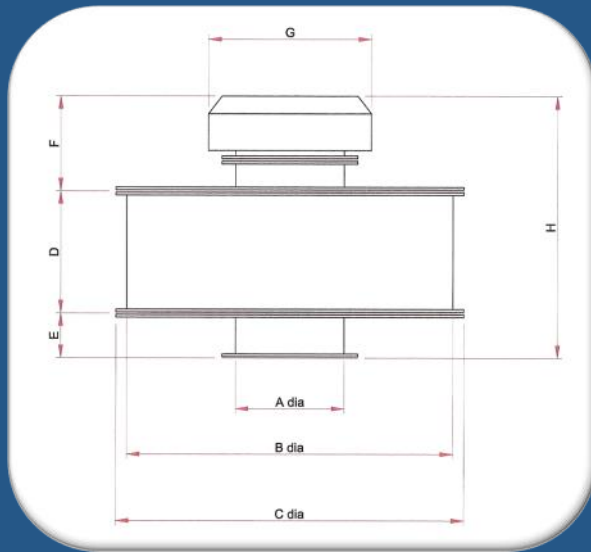

PASSIVE CARBON FILTER

PFCC Range.

APPLICATIONS

- ◇ Sewer Manways Covers.
- ◇ Soil Pipes.
- ◇ Sludge Holding Tank Vents
- ◇ Sewage Holding Tank Vent.
- ◇ Fume Cupboard Vents.
- ◇ Waste Holding Tank Vent
- ◇ Oil Storage VOC Removal.
- ◇ Positive Pressure Wells & Sumps.

OPTIONS

- ◇ Comprehensive range of materials.
- ◇ Cost effective standard range.
- ◇ Bespoke innovative designs.
- ◇ Disposable or fillable filters.
- ◇ Forced vent options available.

Dimension Table.									
Model Ref.	A	B	C	D	E	F	G	H	Volume
PFCC01	110	400	460	400	150	250	200	800	300cu.m/hr
PFCC02	160	500	560	400	150	250	250	800	700cu.m/hr
PFCC03	200	600	660	400	150	250	315	800	1100cu.m/hr
PFCC04	250	700	810	400	150	250	355	800	1700cu.m/hr
PFCC05	315	950	1010	400	150	250	450	800	2700cu.m/hr
PFCC06	355	1100	1200	450	150	250	500	850	3400cu.m/hr
PFCC07	400	1200	1290	450	150	250	560	850	4400cu.m/hr
PFCC08	450	1350	1440	450	150	250	630	850	5600cu.m/hr
PFCC09	500	1500	1600	500	150	250	700	900	6800cu.m/hr
PFCC10	550	1700	1800	500	150	250	770	900	8250cu.m/hr
PFCC11	600	1900	2000	500	150	250	840	900	9900cu.m/hr

All rights are reserved Varicol Design Limited

Other sizes available on application

For further information contact;

Varicol Design Limited Tel: +44 (0) 121 314 1191 Email: sales@varicol.co.uk website: www.varicol.co.uk



CARBON FILTER UNITS Negative Pressure Type.

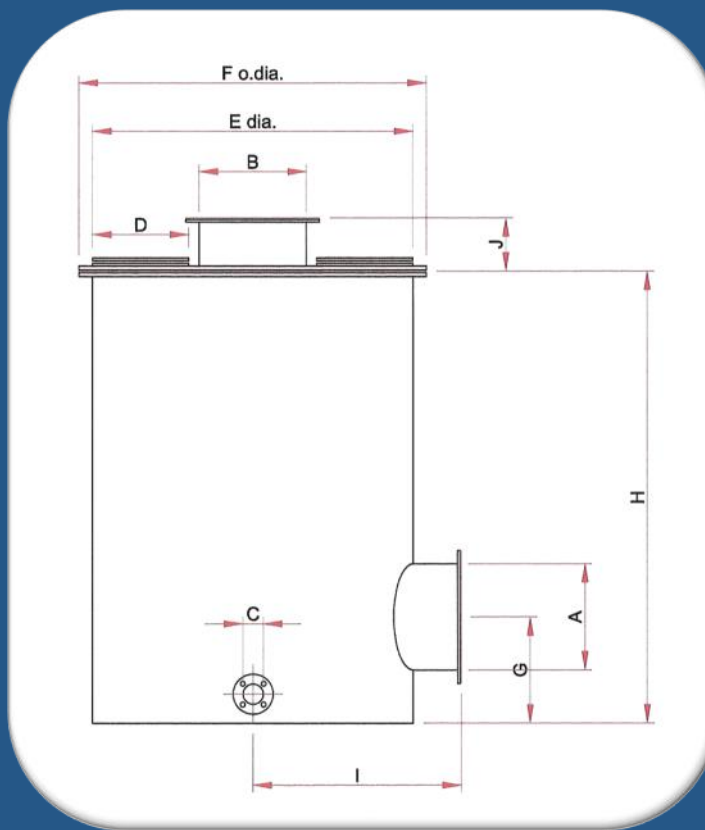

A Flanged Gas Inlet.

B Flanged Gas Outlet.

C Flanged Drain.

D Filling Port.

Dimension Table.

Model Ref.	A	B	C	D	E	F	G	H	J	Volume
CAD01NP	110	110	32	NA	400	500	300	1100	100	300cu.m/hr
CAD02NP	160	160	32	NA	500	600	300	1200	100	700cu.m/hr
CAD03NP	200	200	32	NA	600	700	300	1300	100	1100cu.m/hr
CAD04NP	250	250	32	NA	750	850	300	1400	100	1700cu.m/hr
CAD05NP	315	315	50	NA	950	1050	400	1500	100	2700cu.m/hr
CAD06NP	355	355	50	280	1100	1200	400	1600	100	3400cu.m/hr
CAD07NP	400	400	50	300	1200	1300	400	1700	100	4400cu.m/hr
CAD08NP	450	450	50	300	1350	1450	400	1800	100	5600cu.m/hr
CAD09NP	500	500	50	400	1500	1600	450	1900	100	6800cu.m/hr
CAD10NP	550	550	50	400	1700	1800	500	2000	100	8250cu.m/hr
CAD11NP	600	600	50	400	1900	2000	500	2100	100	9900cu.m/hr



CARBON FILTER UNITS Positive Pressure Type.

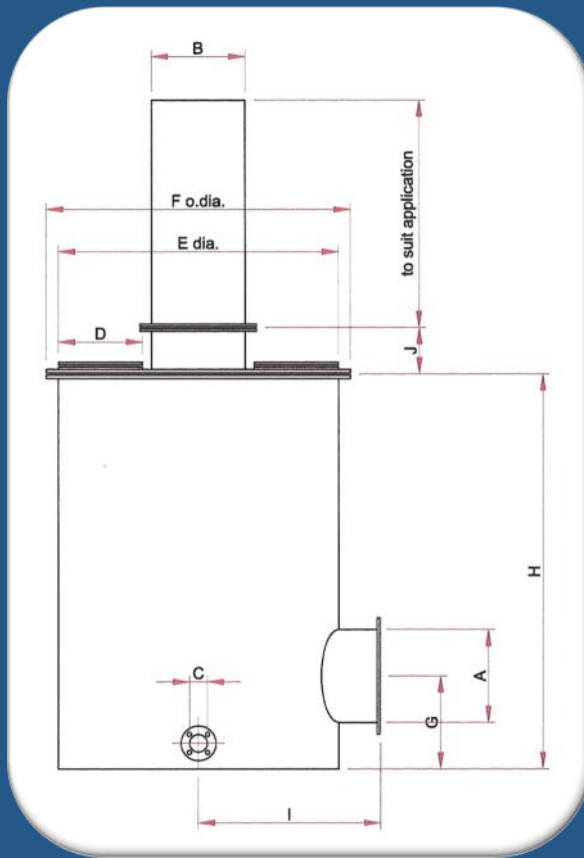

- A Flanged Gas Inlet.
- B Flanged Gas Outlet.
- C Flanged Drain.
- D Filling Port.

Dimension Table.

Model Ref.	A	B	C	D	E	F	G	H	J	Volume
CAD01PP	110	110	32	NA	400	500	300	1100	100	300cu.m/hr
CAD02PP	160	160	32	NA	500	600	300	1200	100	700cu.m/hr
CAD03PP	200	200	32	NA	600	700	300	1300	100	1100cu.m/hr
CAD04PP	250	250	32	NA	750	850	300	1400	100	1700cu.m/hr
CAD05PP	315	315	50	NA	950	1050	400	1500	100	2700cu.m/hr
CAD06PP	355	355	50	280	1100	1200	400	1600	100	3400cu.m/hr
CAD07PP	400	400	50	300	1200	1300	400	1700	100	4400cu.m/hr
CAD08PP	450	450	50	300	1350	1450	400	1800	100	5600cu.m/hr
CAD09PP	500	500	50	400	1500	1600	450	1900	100	6800cu.m/hr
CAD10PP	550	550	50	400	1700	1800	500	2000	100	8250cu.m/hr
CAD11PP	600	600	50	400	1900	2000	500	2100	100	9900cu.m/hr

Other sizes available on application

All rights are reserved Varicol Design Limited

For further information contact;

Varicol Design Limited Tel: +44 (0) 121 314 1191 Email: sales@varicol.co.uk website: www.varicol.co.uk

UK Manufacturing



FUME, MIST & ODOUR CONTROL PLANT & EQUIPMENT.

In 1952 Varicol first started manufacturing at Bayton Road Industrial Estate, Exhall, Coventry, ENGLAND.

Today manufacturing takes place in our modern state of the art manufacturing facility in Birmingham, England, using the latest technology and machinery.

Manufacturing standards include:

BS EN 12573 (Manufacture of Pure Thermoplastic Tanks), BS4994:1987 Categories 1, 2 and 3 (Manufacture of Chemical Resistant Plastic Lined Dual laminate Glass Fibre Reinforced Tanks), DVS 2205 (Calculation of Tanks and Apparatus made of Thermoplastics), BESA's DW154 (Fabrication of Plastic Duct-work) and all other relevant British, European & Global standards.

VARICOL Design Limited

CONSULTING, SALES, SUPPORT

For the territories of

HONG KONG, MACAU & MAINLAND CHINA.

Since 1993 Varicol have been providing fume, mist and odour treatment solutions to Hong Kong.

All fully supported by dedicated local expertise .

Who's highly qualified, experienced and motivated team are dedicated to giving you full local support of all Varicol Products.

FUME, MIST & ODOUR CONTROL PLANT & EQUIPMENT.

Varicol Design Limited

Armoury Road, Small Heath, Birmingham B11 2RH

Tel: +44 (0) 121 314 1191

Email: sales@varicol.co.uk website: www.varicol.co.uk

Dedicated Hong Kong Partner



Cando Trading Limited

13/F Shui On Centre

6-8 Harbour Road

Wai Chai

HONG KONG.

Tel: (852) 2131 9130

Fax: (852) 2877 2015.

eMail: salescando@candotrading.com

VARICOL Design Limited

Registered in the UK

Company No. 10466520